



PermaFlo™ Series Pumps

Durable, high-performance pumps for use with wide range of materials in tough liquid coating applications.

Nordson PermaFlo™ Series pumps* are designed and constructed to withstand the rigors of pumping today's more abrasive, higher solids coatings. Their modular design, patented wear-resistant coating and other proven features meet a wide range of pressure and volume requirements, and assure long service life and low maintenance costs.

Patented Wear-Resistant Coating Design Assures High Performance, Long Life

Plungers and housings of the Nordson PermaFlo™ pumps feature a patented ScoreGuard™ wear-resistant coating that provides superior performance and toughness over other coatings used in wear applications. Twice as hard as conventional hard chrome plating, ScoreGuard coating has excellent corrosion resistance and is warrantied** to provide maximum pump life for superior durability and operating performance.



Heavy-Duty Construction Minimizes Maintenance, Downtime

The heavy-duty design features and construction of the PermaFlo™ pumps facilitate maintenance and minimize associated costs. The quick-disconnect feature between the air motor and hydraulic section, and adjustable upper packings assure easy access to the end-user for longer service life and less downtime.

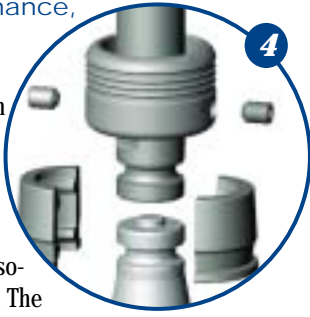

PermaFlo™ pumps have no mechanical shift linkage to wear out and fail, and are designed for easy access to the solvent chamber area to ease routine maintenance. Plus, the external side-mounted air valve design facilitates easy access for installation/maintenance.

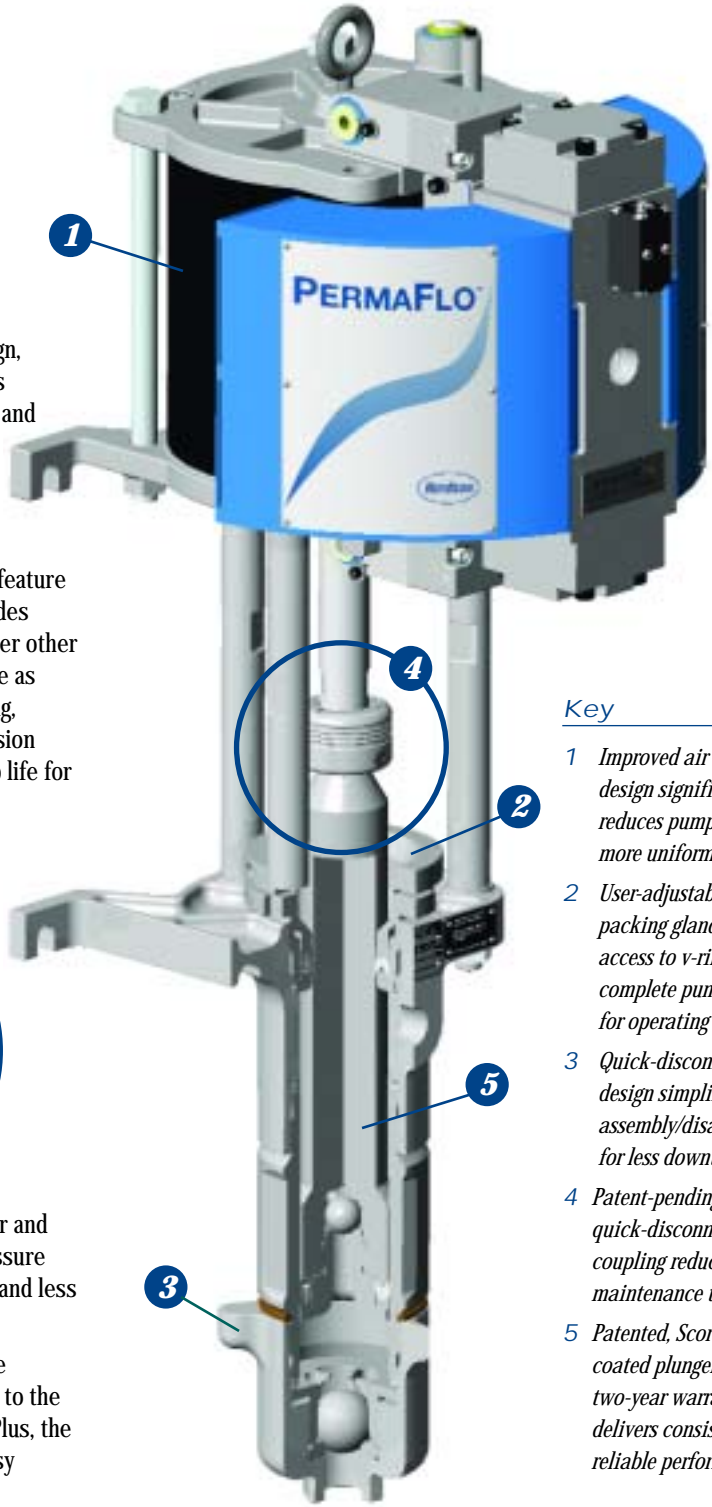

Key

- 1 Improved air motor design significantly reduces pump wink for more uniform coating
- 2 User-adjustable upper packing gland improves access to v-rings without complete pump disassembly for operating flexibility
- 3 Quick-disconnect design simplifies assembly/disassembly for less downtime
- 4 Patent-pending, quick-disconnect coupling reduces maintenance time
- 5 Patented, ScoreGuard™ coated plunger with two-year warranty delivers consistent, reliable performance

PermaFlo 815

* Patent applied for
** Two-year warranty

Improved Operator Safety

PermaFlo™ pumps feature a patent-pending air-piloted valving design that eliminates the over-center spring mechanism used in conventional pumps. This reduces wear on valve parts and contributes to longer service life. The all-pneumatic switching feature meets CE requirements on all exterior pinch points providing improved operator safety.

Easy to Install, Maintain

The external, side-mounted air valve design and integral wall-mount brackets of the PermaFlo™ pumps allow for easy assembly/disassembly, making them ideal for multiple pump applications in large painting kitchens or pump rooms. Integral wall mounting bracket facilitates easy installation and allows for direct retrofit with 180D/360D pumps without changing wall mounts.



Chrome Plating vs. ScoreGuard Coating

In the process to achieve high hardness values with conventional hard chrome plating, several inherent traits like microcracking, high internal stresses and surface imperfections, limit its service life. This can lead to plunger material that more easily scores and eventually results in upper packing leakage and shorter wear life.

Nordson's patented ScoreGuard™ hard-coating process used on plungers and housings eliminates these concerns and significantly improves wear life. The high hardness, low coefficient of friction and low residual stress levels of the coating combine to resist abrasive wear and galling. This results in superior performance and toughness over other coatings used in wear applications.

Twice as hard as conventional hard chrome plating, the metallic silver-colored ScoreGuard coating also has excellent corrosion resistance to assure reliable operating performance.

With a two-year warranty, ScoreGuard coating provides maximum pump life for superior durability even with the most demanding coating applications.

Plunger Coating Comparison

Test results show the ScoreGuard coated plunger polished to mirror-like finish after 24x the cycles of conventional hard-chrome-plating.

Actual Photo



Conventional

Actual Photo



ScoreGuard™

Air Motor Provides Less Pressure Pulsation, Pump Wink

The PermaFlo™ air motor is designed to provide rapid shifts at the end of each stroke without ice buildup that can block flow passages and stall the pump. Combined with the well-guided pressure and siphon ball checks in the hydraulic section, the air motor maintains constant pressure at the nozzle, practically eliminating the pump wink typically associated with conventional reciprocating pumps. This results in no visible collapse in spray pattern, and uniform, consistent film build on the finished product.

In addition, PermaFlo™ pump muffler design meets OSHA requirements for safe operation without hearing protection.

Plunger with Patented ScoreGuard™ Coating

The demand to meet ongoing environmental restrictions for safer, cleaner finishing operations continues to spur development by coating manufacturers for new, unique and more durable liquid materials that are more abrasive and difficult to spray.

To accommodate use of these coatings, Nordson has developed patented ScoreGuard™ coated pump plungers to provide superior performance and toughness over other coatings used in wear applications.

With a two-year warranty, Scoreguard™ coating provides maximum pump life for durable, reliable operation even in the most demanding spray application environments.

***Teflon is a registered trademark of E.I. du Pont de Nemours and Company

- Waterbornes
- Abrasive high-solids paints
- Heavy-bodied protective and maintenance coatings, including organic and inorganic zincs
- Heavy primers, including coal tar epoxy
- Vinyls
- Sealers
- Undercoatings
- Acrylic emulsions and adhesives

Air Motor

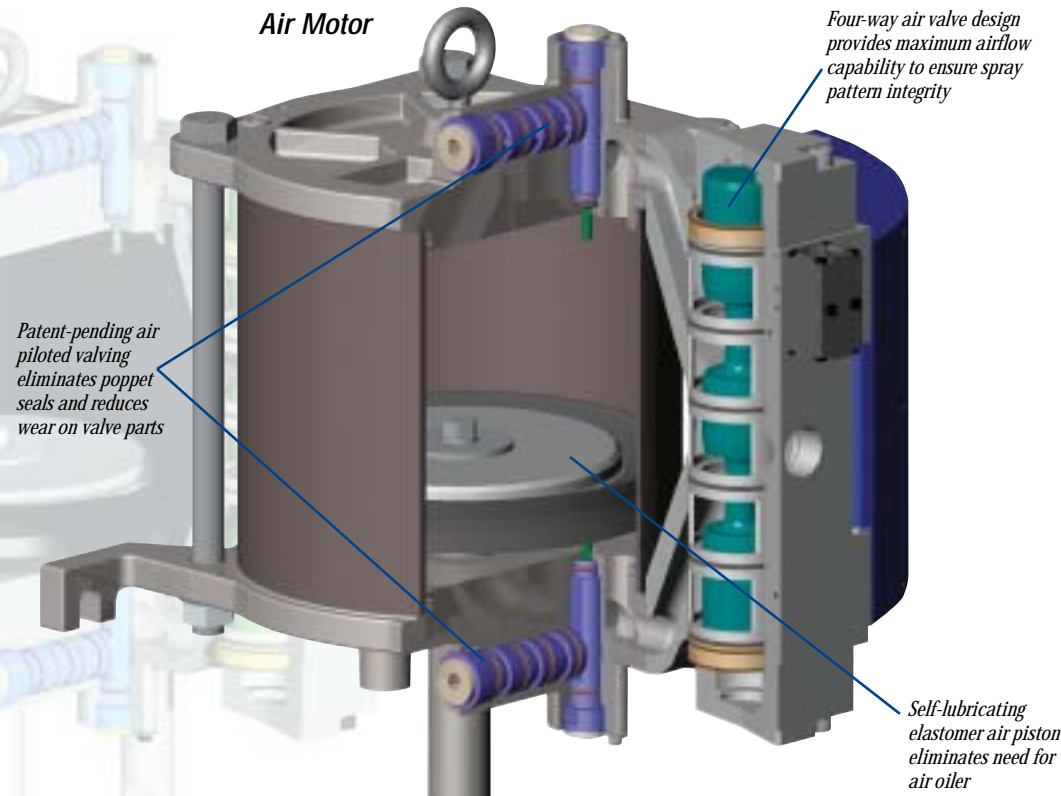

Four-way air valve design provides maximum airflow capability to ensure spray pattern integrity

Patent-pending air piloted valving eliminates poppet seals and reduces wear on valve parts

Self-lubricating elastomer air piston eliminates need for air oiler

Plunger with ScoreGuard Coating

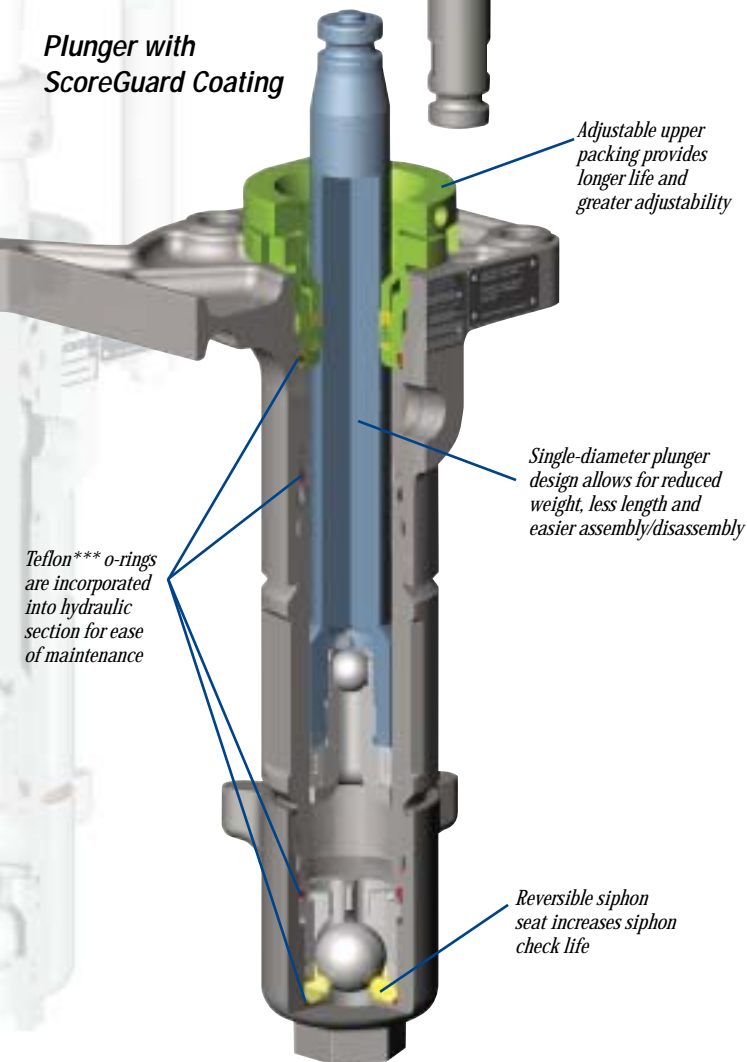

Adjustable upper packing provides longer life and greater adjustability

Single-diameter plunger design allows for reduced weight, less length and easier assembly/disassembly

Teflon*** o-rings are incorporated into hydraulic section for ease of maintenance

Reversible siphon seat increases siphon check life

PermaFlo™ 830

Pump Wink Comparison



Pattern collapse with traditional technology

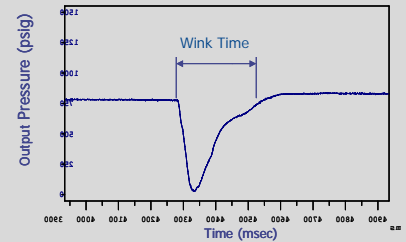

Pattern collapse with PermaFlo™ 830 pump

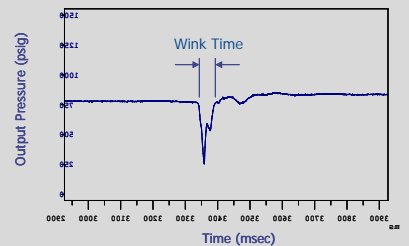



Tests performed using water and Nordson® A7A airless guns and proprietary Cross-Cut nozzles.

PermaFlo™ Series Pumps

Summary of Features and Benefits

- Patented ScoreGuard™ wear-resistant coating process used on plungers and housings provides superior performance and toughness over other coatings used in wear applications for superior durability and performance.
- Quick-disconnect design of air motor and hydraulic section minimizes maintenance.
- Adjustable upper packings give control to user to minimize downtime and ensure longer life.
- Air motor provides rapid shifts at the end of each stroke without ice build-up to minimize stalling for continuous operation.
- Air motor and well-guided pressure and siphon ball checks produces substantially less pressure pulsation (pump wink) than conventional reciprocating pumps to provide uniform film build on the finished product.
- External side-mounted air valve provides for easy access and provides long life.
- All stainless steel wetted parts construction accommodates a wide range of coating applications.
- PermaFlo™ pump muffler design meets OSHA requirements for safe operation without hearing protection.
- Self-lubricating elastomers allow for use of non-lubricated air that satisfies newer EPA requirements stating that air contaminated with oil cannot be exhausted into the environment.
- Integral wall mounting bracket facilitates easy installation and allows for direct retrofit with 180D/360D pumps without changing wall mounts.

Specifications

Pump Model	PermaFlo™ 815	PermaFlo™ 830
		
Part Number	P/N 1024648	P/N 1023362
Fluid/Air Ratio	15:1	30:1
Air Motor Diameter Stroke	203mm (8.0 in) 119mm (4.7 in)	203mm (8.0 in) 119mm (4.7 in)
Fluid Delivery at 60 cycles*/min 1/min (gpm) Liters (gal)/cycle*	30.8 (8.16) 0.51 (0.136)	14.8 (3.92) 0.24 (.065)

* 1 Cycle = 2 strokes (1 up and 1 down)

Accessory Equipment

Description	Part Number	Main Components
Air Motor Accessory Group	P/N 1029320	Regular Assy w/Filter Air Gage 0-100psi
Stainless Steel Siphon Accessory Group	P/N 170120	Strainer, Hose, Siphon Rod
Stainless Steel Circulation Kit	P/N 1029257	Circulation Valve, Fittings, Connectors

Nordson reserves the right to make design changes to products to improve their function. These changes may occur between printings.

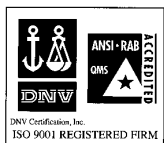

For more information, talk with your Nordson representative or contact your Nordson regional headquarters office.

United States

Amherst, Ohio
Telephone: (800) 955-9563
Facsimile: (440) 985-1536
Web: www.nordson.com/liquid
Email: liquidmarketing@nordson.com

www.nordson.com

Canada

Markham, Ontario
Telephone: (800) 463-3200
(905) 475-6730
Facsimile: (905) 475-8821
Web: www.nordson.ca

Europe

Erkrath, Germany
Telephone: (49) 211-9205-0
Facsimile: (49) 211-254658

Japan

Tokyo, Japan
Telephone: (81) 3-5762-2700
Facsimile: (81) 3-5762-2701

Asia/Australia/Latin America

Amherst, Ohio
Telephone: (440) 985-4000
Facsimile: (440) 985-1096
24-hour message service:
(440) 985-4797
Email: psd_customerservice@nordson.com

