

Model A7AA Air-Assisted Airless Gun



Compact, high-cycle, air-assisted airless gun for spraying highly viscous and difficult-to-atomize coatings in high-production automatic spraying applications.

The Nordson Model A7AA air-assisted airless gun is a compact, high-speed, automatic spray gun designed to spray viscous and hard-to-atomize coatings. The gun is available in non-circulating or circulating versions when installed in heated systems, or in production situations when continuous circulation of fluids is desirable.

Combining Nordson's patented Cross-Cut airless nozzle technology with a small volume of atomizing air, the A7AA gun achieves superior atomization without using high airless pressure. The A7AA is compatible with a wide range of difficult-to-spray coatings and adhesives, including: paint; protective coating; sealer and undercoating; cold glue; heated wax; solvent and waterbase adhesive; acrylic emulsions; sprayable hot melt adhesive; and food and drug applications.

The A7AA gun provides high-speed triggering capability without spitting and dripping. Fast on/off response time allows for high-speed cycling in "stitching" operations and exceptional needle and seat life in abrasive applications. In very high-speed stitching applications, the air-assist feature can be adjusted for a continuous air bleed to minimize the spitting problems associated with spray guns when subjected to high-cycle applications.



Stainless steel model of the A7AA gun

Cross-Cut Airless Nozzles

The Model A7AA gun uses patented Nordson Cross-Cut® nozzles which provide improved atomization with a wide range of materials including highly viscous and difficult-to-atomize coatings. At a given fluid pressure, Cross-Cut nozzles produce greater atomizing energy compared to conventional airless spray nozzles. The result is a softer, low-velocity spray which helps minimize dripping, material waste and equipment wear for a cleaner, more efficient operation.



Nordson Cross-Cut nozzles

Benefits of Heated Coatings

Adding patented Nordson NH-4 fluid heaters to a circulating system featuring A7AA guns helps reduce and control the viscosity of coating materials without adding solvents. This can boost painting efficiency by reducing solvent costs and over-spray. Heating the coating material further improves atomization and also improves finish quality by providing a more uniform, higher-solids film with single-coat applications.

Heated A7AA gun systems can be used to reduce drying time, increase dry film thickness, improve atomization for a better finish, and minimize or eliminate blushing with lacquer and vinyl coating materials.

Model A7AA Air-Assisted Airless Gun

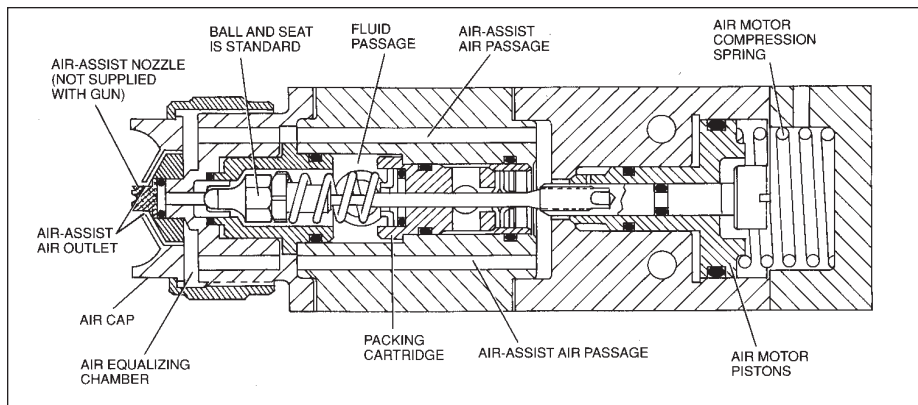

Plan view of the A7AA gun

Features and Benefits

- **Compact, simple design** — ensures easy installation, reliable operation and low maintenance costs.
- **Carbide ball and seat design** — provides long life and easy replacement for reduced maintenance and downtime costs.
- **Flexible application** — for use with cold or heated systems.
- **Rugged, production-proven construction** — ensures maximum on-line production capability, and low downtime and maintenance costs.
- **Air-assist design** — can atomize higher-solid fluids better than standard airless guns for greater operating flexibility.
- **Increased painting control** — reduces runs and sags to ensure better coating quality on small or irregular parts.
- **Fast cycling capability with positive cutoff** — provides precise operation with minimal dripping or spitting.
- **Available with stainless-steel wetted parts** — to accommodate production requirements of waterborne and corrosive applications.
- **Low pressure operation** — minimizes overspray, reducing painting costs and equipment wear, and lowering booth maintenance and disposal costs.
- **Increased operating flexibility** — A7AA gun can be easily retrofitted to existing automatic airless applications.
- **Standard with Nordson Cross-Cut nozzles** — provide improved atomization and precise paint distribution. Eliminate tails when spraying high-solids and difficult-to-atomize coatings. Ensure better paint quality and minimize re-work costs.

Specifications

Dimensions

Height	(76.2 mm)	3.0 in.
Length	(147.3 mm)	5.8 in.
Width	(101.6 mm)	4.0 in.

Weight

(1.4 kg) 3.09 lbs.

Maximum Fluid Pressure

(105.5 kg/cm²) 1500 psi

Where Air-Assist is Best Applied

- Spraying catalyzed materials where heated systems cannot be used.
- Waterborne coatings where air entrapment occurs with airless atomization.
- For simple, non-circulating, cold glue and adhesive applications.
- Where airless atomizing pressures cause overspray and poor coating quality.
- Where airless atomization is marginal to remove "tails."
- For low-flow airless applications to minimize nozzle plugging.
- For a better degree of flow control at individual guns compared to airless. Typical fluid pressure range is 200 to 1,000 PSI.
- To apply sealers, undercoatings and waxes.

Nordson reserves the right to make design changes to products to improve their function. These changes may occur between printings.

For more information, talk with your Nordson representative or contact your regional headquarters office.

United States
Amherst, Ohio
Telephone: (800) 955-9563
Facsimile: (440) 985-1536
www.nordson.com

Canada
Markham, Ontario
Telephone: (905) 475-6730
Telephone: (800) 463-3200
Facsimile: (905) 475-8821
www.nordson.ca

Europe
Erkrath, Germany
Telephone: (49) 211-9205-0
Facsimile: (49) 211-254658

Japan
Tokyo, Japan
Telephone: (81) 3-5762-2700
Telephone: (81) 3-5762-2701

Asia/Australia/Latin America
Amherst, Ohio
Telephone: (440) 988-9400
24-hour message service:
(440) 985-9421
Facsimile: (440) 985-3710
24-hour facsimile:
(440) 985-1096



When you expect more.™